

COMSATS University Islamabad
Sahiwal Campus

TENDER DOCUMENTS

For

**Procurement of I.T Items and Furniture & Fixture for Auditorium of CUI
Sahiwal Campus**

(Single Stage Two Envelop Procedure)

Submission and Opening Date for Tender:

March 25, 2022 (Friday)

Submission Time for Technical and Financial Proposals: 1030 hours

Opening Time (only Technical Proposals): 1100 hours

Tender Issued to M/s _____

March 2022



Purchase and Store Department

COMSATS Road, Off G.T.Road, Sahiwal

Tel: 040-4305666-Ext-128 & 186

Web: <https://www.sahiwal.comsats.edu.pk/Tenders.aspx>

Signature & Stamp of Bidder



COMSATS University, Islamabad
Sahiwal campus

COMSATS Road, Off G.T.Road, Sahiwal
Tel: 040-4305001-7 Web: www.cuisahiwal.edu.pk

Tender Notice
(No. COMSATS/SWL/1002/21-22/18.02.22)

COMSATS University, Islamabad (CUI), Sahiwal Campus, a public sector University of Ministry of Science and Technology invites sealed bids for the following works: -

1. Interior designing of Auditorium (Civil, Electrical Works & Fire Alarm System)
2. Procurement of furniture & fixture for Auditorium
3. Procurement of IT items for Auditorium

Term & Conditions for Serial No. 01

1. Sealed bids are invited from the reputed firms/Contractors registered with Pakistan Engineering Council in category C-5 or above having expertise in Interior designing and registered with Income tax and Sales tax Departments and who are also on Active Tax Payers List (ATL) of FBR. Bidding documents comprising of detailed terms and conditions, method of procurement, procedure for submission of bids, bid security, bid validity, opening of bid, clarification/rejection of bids, performance guarantee etc. are available for the interested bidders at **“Works Department, COMSATS Road, Off G.T. Road, Sahiwal”**. Non-refundable fee of bidding document is **Rs. 5000 (Five Thousand only)** in form of pay order/Demand Draft in favor of CUI, Sahiwal Campus.
2. The bids, prepared in accordance with the instructions in the bidding documents accompanied by a bid security equivalent of two percent (2%) of the bid price, must reach at **“Works Department, COMSATS Road, Off G.T. Road, Sahiwal”** on or before **1030 hours** on **March 25 (Friday), 2022**. Bids will be opened at **1100 hours** on the same day, in the presence of bidder's representatives who choose to attend at the same address. This advertisement is also available on PPRA website at www.ppra.org.pk and on the Campus Website at <https://www.sahiwal.comsats.edu.pk/Procurement/Tenders.aspx>.

Term & Conditions for Serial No. 02 & 03

1. Sealed bids are invited from the authorized distributors /reputed firms/general order suppliers registered with Income tax & GST department and who are also on Active Tax Payers List (ATL) of FBR. Bidding documents comprising of detailed terms and conditions, method of procurement, procedure for submission of bids, bid security, bid validity, opening of bid, evaluation criteria, clarification/rejection of bids, performance guarantee etc. are available for the interested bidders at **“Works Department, COMSATS Road, Off G.T. Road, Sahiwal”**. Non-refundable fee of bidding

Signature & Stamp of Bidder

document is **Rs. 5000 (Five Thousand only) for each tender** in form of pay order/Demand Draft in favor of CUI, Sahiwal Campus.

2. Procedure of open competitive bidding will be **“Single Stage Two Envelope”**. Financial bids must be accompanied by a bid security equivalent of two percent (2%) of the bid price.
3. The bids marked separately **“Technical” and “Financial”** and prepared in accordance with the instructions in the bidding documents, must reach at **“Works Department, COMSATS Road, Off G.T.Road, Sahiwal”** on or before 1030 hours on **March 25 (Friday), 2022**. Initially, only the envelope marked **“Technical proposal”** will be opened at **1100 hours** on the same day, in the presence of bidder's representatives who choose to attend. This advertisement is also available on PPRA website at www.ppra.org.pk and on the Campus Website at <https://www.sahiwal.comsats.edu.pk/Procurement/Tenders.aspx>.



ALI SHAIR
Incharge Works/Assistant Engineer
COMSATS University, Islamabad
Sahiwal Campus, COMSATS road off G.T road
works@cuisahiwal.edu.pk

TERMS AND CONDITIONS OF THE TENDER

1. **Eligible Bidders.** - Bidding is open to all firms and persons meeting the following requirements:
 - a) Registered with Income and Sales Tax Departments, Government of Pakistan
 - b) and who are on Active Taxpayers List (ATL) of Federal Board of Revenue (FBR), Government of Pakistan.

2. **Tender Document Fee (Non-Refundable).** - Bidding documents along with Pay Order / Demand Draft amounting to **Rs. 5000/-** as a tender documents fee (Non-Refundable) shall be submitted in favor of COMSATS University Islamabad, Sahiwal Campus to the address given below. No bid will be accepted without tender documents' fee. Attach tender document fee with Technical Proposals.

3. **Bid Security (Refundable).** - The bidder is required to furnish in the form of Deposit at Call (CDR) or a Bank Guarantee issued by a Scheduled Bank in Pakistan equivalent to 2% of the total bid price as a Bid Security in favor of "COMSATS University Islamabad, Sahiwal Campus. Any bid not accompanied by an acceptable bid security shall be rejected by the Employer as non-responsive and without any right of appeal. Attach Earnest money with Financial Proposals.
 - a. The bid securities of unsuccessful bidders will be returned upon award of contract/Issuance of Purchase Order to the successful bidder or an expiry of validity of Bid Security whichever is earlier.

 - b. The Bid Security may be forfeited:
 - i. If a bidder withdraws his bid during the period of bid validity

 - ii. If a bidder does not accept the correction of his bid price

 - iii. in case of a successful bidder, if he fails to sign the contract agreement or execute the work as specified in bill of quantities (BoQ).

4. **Performance Guarantee (Refundable): The Warranty is one year.** However, 10% of the total value of the Invoice or a Bank Guarantee issued by a Scheduled Bank in Pakistan will be retained as security by COMSATS University Islamabad, Sahiwal Campus which will be released after one year from the date of delivery / completion of work / supply. Insurance Guarantee is not acceptable. After finalization of the bid and signing contract performance guarantee is required to be submitted and bid security is to be released.

5. **Bid validity.** - All prices should be valid for at least **90 days.** Withdrawal or any modification of the original offer within the validity period shall entitle CUI to forfeit the

earnest money in favor of the CUI and / or put a ban on such vendor participation in CUI tenders / works

6. All prices should be quoted on F.O.R (Pak Rupees).
7. **Delivery time or Completion Schedule.** - The exact completion/delivery time from the date of the purchase / work order will be **30 days**. The handing over / completion time for this contract is of critical importance.
8. The bid proposal should be inclusive of freight and all other taxes and we need delivery of items at COMSATS University Islamabad, Sahiwal Campus's premises.
9. All pages (BoQs & Terms & Conditions) are mandatory to be signed / stamped, failing which the bid may be rejected
10. Any addition, deletion or modification of any clause of the procurement terms & conditions of CUI by any vendor will not be acceptable and may lead to rejection of the bid.
11. **Site Visits/Concerned Office.** - Before quoting, the Bidder in his own interest can visit the **Store Section of CUI Sahiwal Campus/Concerned Office for sample/specifications/requirements of each item** and to know the full implications of the assignment. This will help him in proper assessment of the work. Failure to do so will not absolve the contractor of his responsibility to carry out the work as specified in the tender documents. The cost of visiting the site shall be borne by the Tenderer and shall be at his own responsibility and risk.
12. The bid form (BoQs) must be duly filled in, stamped and signed by the authorized representative of the bidder.
13. **Method of Procurement.** – COMSATS University Islamabad, Sahiwal Campus, will follow the PPRA rule of **single stage two envelope procedure**;
 - i. The bid shall comprise a single package containing **Two Separate Envelopes**. Each envelope shall contain separately the **Financial Proposal** and the **Technical Proposal**;
 - ii. The envelopes shall be marked as “**FINANCIAL PROPOSAL**” and “**TECHNICAL PROPOSAL**” in bold and legible letters to avoid confusion;
 - iii. Initially, only the envelope marked “**TECHNICAL PROPOSAL**” shall be opened;
 - iv. The envelope marked as “**FINANCIAL PROPOSAL**” shall be retained in the custody of the procuring agency without being opened;

- v. The procuring agency shall evaluate the technical proposal in a manner prescribed in advance, without reference to the price and reject any proposal which does not conform to the specified requirements;
- vi. During the technical evaluation no **amendments** in the technical proposal shall be permitted;
- vii. The financial proposals of bids shall be opened publicly at a time, date and venue announced and communicated to the bidders in advance;
- viii. After the evaluation and approval of the technical proposal the procuring agency, shall at a time within the bid validity period, publicly open the financial proposals of the technically accepted bids only. The financial proposal of bids found technically nonresponsive shall be returned un-opened to the respective bidders;
- ix. and the bid found to be the lowest evaluated bid shall be accepted.

14. Submission and Opening of bids. - The bid should be submitted in a sealed envelope in such manner that the contents are fully enclosed and cannot be known until duly opened. The sealed bids (Technical and Financial Proposals) must reach up to **March 25, 2022 (Friday)** on or before **1030 hours** and will be opened on the same date **at 1100 hours** in the presence of available bidders. All bids submitted after the time prescribed shall be rejected and returned without being opened.

15. The envelope should be marked as under;

Secretary, Purchase Committee
COMSATS University Islamabad, Sahiwal Campus
COMSATS Road, Off G.T Road, Sahiwal.
Tel: 040-4305001-05, Ext: 128

The envelope shall also bear the word “CONFIDENTIAL” and following identification quotation of **“Procurement of I.T Items and Furniture & Fixture for Auditorium of CUI Sahiwal Campus”**.

16. After opening of bids, COMSATS University Islamabad, Sahiwal Campus will examine the bids for completeness as per tender document.

17. Evaluation Criteria: Technical bids will be evaluated on the basis of following criteria:

- Tender will be evaluated on **Grand Total Basis** for Part-A and on **Item Wise Basis** for Part-B for Auditorium of CUI, Sahiwal Campus
- The bidder can participate in one part OR in both parts of the tender.

Signature & Stamp of Bidder

- The bidder will provide literature of quoted brands which will be evaluated as per specifications provided in tender documents.
- Complete Company profile with HR Strength, National and General Sales Tax Numbers, year of establishment and client lists.
- Experience of the firm for supplying of IP Cameras/Access Points/IT Accessories to any Federal or Provincial Government Department, Agency, Organization or autonomous body or Private Sector Organization anywhere in Pakistan. Please attach Purchase Orders/Work Orders with technical proposals.
- Tenderer is a bidder who has not been blacklisted by any Federal or Provincial Government Department, Agency, Organization or autonomous body or Private Sector Organization anywhere in Pakistan. The vendor will provide this undertaking on judicial stamp paper with Technical Proposal.

18. Evaluation of bids. - Bids will be evaluated in accordance with the evaluation criteria and other terms and conditions set forth in the bidding documents.

19. Clarification of bids. - After opening of bids, bidders are not allowed to alter or modify his bid. However, the procuring agency may seek and accept clarifications to the bid that do not change the substance of the bid.

20. The Tender shall be checked for any arithmetic errors which shall be rectified. The Tender Price as determined after arithmetic corrections shall be termed as the Corrected Total Tender Price which shall binding upon the Tenderer.

21. One Bid per Bidder. - Conditional or alternative bids are not allowed. Bidders are required to quote one bid/one brand. If bidders quote two bids/different brands then their bids are liable to be rejected.

22. COMSATS University Islamabad, Sahiwal Campus reserves the rights to reject the bid if;

- i. Received without earnest money
- ii. Received later than the date and time fixed for tender submission
- iii. The tender is unsigned/ unstamped
- iv. The offer is ambiguous
- v. The offer is conditional
- vi. Offer is made by the unauthorized agent/ supplier of the original equipment manufacturer.
- vii. The offer is from a firm, which is black listed by any Govt. Office.

- viii. The offer is received by telephone/telex/fax/telegram.
- ix. Any unsigned / ambiguous erasing, cutting / overwriting etc. is made.

- 23.** It is the sole responsibility of the agent / supplier / manufacturer to comply with the applicable laws, be national or international.
- 24.** Purchase order (s) will be awarded to the lowest or technically recommended bidder (s) on the basis of item wise / subtotal wise / grand total wise according to the nature of BoQs.
- 25. Rejection of bids.** - COMSATS University Islamabad, Sahiwal reserves all the rights to reject all bids or proposals at any time prior to the acceptance of a bid or proposals. CUI Sahiwal will communicate the grounds for rejection of bids upon request of any supplier or contractor but not liable to justify those grounds
- 26.** The contract will be executed and handed over in satisfactory conditions up to the entire satisfaction of COMSATS University Islamabad, Sahiwal Campus
- 27. If the vendor fails to deliver the goods / services to CUI-Sahiwal in time then the penalty will be charged as under: -**
- a. 0.5% per day of the Purchase Order for the first 10 working days.
 - b. 0.75% per day of the Purchase Order, after that, up to a maximum of 10% of sum stated in the Purchase/Work Order. Once the maximum is reached, the Purchaser may terminate the contract pursuant to tender clause 35, earnest money and payment may be forfeited.
- 28.** If the delivered goods / services are not according to the required quality standards / specifications, the same shall be liable to be rejected after inspection. The vendor would be required to supply as per requirements mentioned in our BoQs, otherwise the purchase / work order will be cancelled after due date with confiscation of earnest money.
- 29.** The Employer will inspect the supplied and provided items to verify their conformity to the Technical Specifications given in BoQ. The inspection will be conducted at final destination.
- 30. On account payments.** - Part / Advance payments are not allowed. Payment will be made on submission of Invoice in the name of “COMSATS University Islamabad, Sahiwal Campus” with a copy of delivery challan (s) after the complete order has been supplied, inspected and accepted which includes delivery / installation, and COMSATS acceptance / inspection thereof.
- 31.** Deduction of Income Tax and any other tax will be deducted at source according to Government prevailing rules.

- 32. Blacklisting of Suppliers and Contractors.** - A procuring agency can permanently or temporarily bar from participation in its respective procurement proceedings, the suppliers and contractors who either consistently failed to provide satisfactory performances or found to be indulging in corrupt or fraudulent practices.
- 33.** In case of any dispute, decision of the Director, CUI Sahiwal will be final and binding upon the parties.
- 34.** The quantities given in the Bill of Quantities are estimated and provisional, and are given to provide a common basis for bidding. The basis of payment will be the actual quantities of work executed and measured by the Bidder and verified by the Department/Concerned Office and valued at the rates and prices entered in the priced Bill of Quantities, where applicable, and otherwise at such rates and prices as the Employer may fix as per the Contract.
- 35.** The CUI reserves the right to modify the quantities of goods / services at any time before the award of purchase / work order.
- 36.** In case of repeat orders fifteen per cent (**15%**) of the Original Procurement will be considered as the permissible limit to issue variation.
- 37.** The bidder should furnish a certificate as worded below in token of acceptance of all the terms and conditions of the tender. Otherwise, the tender will not be considered under any circumstances.

38. I / We hereby confirm to have read carefully the terms and conditions of your Tender Enquiry dated for opening on..... for the purchase of

We agree to abide by all these terms and conditions/instructions.

39. Certified that the prices quoted against advertises tender dated..... are not more than the prices charged from any other purchasing agencies in the county in the financial year..... and in case of any discrepancy, We/I hereby undertake to refund the price charged in excess if and when asked to do so.

40. Certified that the prices quoted by our firm are inclusive of G.S.T and all taxes as per rules and regulations.

Company / Vendor Name:.....

Name of Tenderer:.....

Postal Address:.....

Tel. / Mobile:.....**Email:**.....

NTN#:.....**GST#:**.....

C.N.I.C No:.....

Signature of Tenderer:.....

Date and Stamp:.....

- Please also attach the Certificate supporting being Active Taxpayer as per requirement of FBR.

Part-A-of the Tender

Bill of Quantities (BoQ) (Grand Total Basis)

Procurement of I.T Items for Auditorium of CUL Sahiwal Campus

Sr.#	Item Name & Specification	Qty		Rates to be quoted inclusive of all taxes, installation and Delivery Charges		
				Quoted Model/Brand	Unit Price (Rs)	Total Price (Rs)
1	<p>Cloud Managed Wireless Access Point Indoor with 5 Years Enterprise License, POE adapter/Injector, accessories with complete installation in all respect.</p> <p>Wireless Access Point: (Qty 02)</p> <p>Radios: 4x4:4 MU-MIMO 802.11ax</p> <ul style="list-style-type: none"> • 2.4 GHz 802.11b/g/n/ax client access radio • 5 GHz 802.11a/n/ac/ax client access radio • 2.4 GHz and 5 GHz dual-band WIDS/WIPS, spectrum analysis, and location analytics radio • 2.4 GHz Bluetooth Low Energy (BLE) radio with beacon and scanning support • Concurrent operation of all four radios <p>Antenna: Internal antenna (5.4 dBi gain at 2.4 GHz, 6 dBi gain at 5 GHz)</p> <p>802.11ax, 802.11ac Wave 2 and 802.11n Capabilities:</p> <ul style="list-style-type: none"> • DL-OFDMA, UL-OFDMA, TWT support, BSS coloring • 4 x 4 multiple input, multiple output (MIMO) with four spatial streams • SU-MIMO, UL MU-MIMO**, and DL MU-MIMO support • Maximal ratio combining 	No	02			

Signature & Stamp of Bidder

<p>(MRC) & beam forming</p> <ul style="list-style-type: none"> • 20 and 40 MHz channels (802.11n); 20, 40, and 80 MHz channels (802.11ac Wave 2); 20, 40 and 80 MHz channels (802.11ax) • Up to 1024-QAM on both 2.4 GHz and 5 GHz bands • Packet aggregation <p>Security:</p> <ul style="list-style-type: none"> • Integrated layer 7 firewall with mobile device policy management • Real-time WIDS/WIPS with alerting and automatic rogue AP containment with Air Marshal • Flexible guest access with device isolation • VLAN tagging (802.1q) and tunneling with IPsec VPN • PCI compliance reporting • WPA, WPA2-PSK, WPA2-Enterprise with 802.1X, WPA3 - Personal, WPA3 - Enterprise, WPA3 - Enhanced Open (OWE) • EAP-TLS, EAP-TTLS, EAP-MSCHAPv2, EAP-SIM • TKIP and AES encryption • Enterprise mobility management (EMM) and Mobile device management (MDM) integration • Cisco ISE integration for guest access and BYOD posturing <p>Quality of Service: WMM access categories with DSCP and 802.1P support.</p> <p>Layer 7 application traffic identification and shaping.</p> <p>Power: Power over Ethernet (POE) Injector and DC adapter</p> <p>Interface: 1x100/1,000/2.5G Base-T Ethernet (RJ45) 1xDC power connector</p> <p>Mounting Kit: Standard mounting kit (Desktop, Ceiling and wall mount capable)</p>					
--	--	--	--	--	--

	<p>Enterprise License: 05 Years Warranty: Standard Manufacturer Warranty Onsite Supply and Installation of Material Scope of Work: Supply & Installation a) Installation of Access Points. (Complete in all respect) b) Installation of Network Cable (CAT 6 UTP 23AWG): Laying of three cables (two for access points and one for Dice/Rostrum) from Auditorium to IT Office. c) Installation of power cable & multi socket light plug: 40*0.0076 2 cores copper flexible. 10 In 1 multi socket light plug with PVC back box d) Installation of duct or PVC pipe. Duct Size 40*40, PVC Pipe: 1-1/4".</p>					
2	<p>Multimedia Projector: (Qty 02) WUXGA LCD Multimedia Projector Projector Type: LCD Resolution: WUXGA (1900*1200 pixels) Light Source: Laser Diodes Light Output: 6000 Lumens Contrast Ratio: 3,000,000:1 (all white/ all black) Aspect Ratio: 16:10 Screen Size(diagonal): 0.76-7.62 m (30-300 in) Lens: 1.6 x Manual zoom (Throw ratio: 1.09–1.77:1) Manual focus lens, F = 1.60–2.12, f = 15.30–24.64 mm Lamp Life Hours: 20,000 hours (Normal) Keystone Correction range: Vertical: ± 25°, Horizontal: ± 35° Video Input: HDMI, VGA (Compatible with HDCP, Deep</p>	No	<p>Multimedia Projector: 02 HDMI Splitter: 01 Ceiling Mount Kit: 02</p>			

<p>Color) Input Signal Search: Auto Signal Support Input: 4K/30p supported Network Port: RJ45 Accessories: Remote with batteries, Carrying bag Warranty: One year onsite HDMI Splitter with installation: (Qty 01) 4Kx2K UHD HDMI Splitter 1x4 Signal Format: 3D, Deep Color, 4K*2K 30Hz downward compatible with 1080 P HDMI Signal Bandwidth: 340 MHz/3.4 Gbps HDMI Version 1.4, HDCP 1.4 Compliant EDID Support: Automatic recognition Installation Method: Plug & Play Audio format: DTS-HD, Dolby-true HD, LPCM7.1, DTS, DOLBY-AC3, DSD, HD (HBR) With signal connection indicator, the corresponding channel will be lighted automatically if have signal output. Warranty: One year onsite Ceiling mount Kit: (Qty 02) Ceiling mount Kit: High quality & compatible with all multimedia projectors Length: 3'.7" ~ 6'.3" adjustable size Load bearing: Heavy Duty Max Load up to 35 KG</p>					
--	--	--	--	--	--



Supply and Installation of Material:

Scope of Work: Supply & Installation

- a) Installation of multimedia projector & mounting kit. (Complete in all respect)
- b) Installation of power cable & multi socket light plug:
40*0.0076 2 cores copper flexible.
5 In 1 multi socket light plug with PVC back box.
- c) Installation of duct or PVC pipe.
Duct Size 16*38. PVC Pipe: 3/4".
- d) Installation of HDMI cables 5m/10m/15m/20m: (Resolution supported 2k.4k)
HDMI 2.0/2.1 UHD 4 K Cables 5m/10m/20m 2.0V (ult/jasoz) setup for same display simultaneously from rostrum to multimedia.

	<p>Supply and Installation of Material: Scope of Work: Supply & Installation</p> <ul style="list-style-type: none"> a) Installation of multimedia projector & mounting kit. (Complete in all respect) b) Installation of power cable & multi socket light plug: 40*0.0076 2 cores copper flexible. 5 In 1 multi socket light plug with PVC back box. c) Installation of duct or PVC pipe. Duct Size 16*38. PVC Pipe: 3/4". d) Installation of HDMI cables 5m/10m/15m/20m: (Resolution supported 2k.4k) HDMI 2.0/2.1 UHD 4 K Cables 5m/10m/20m 2.0V (ult/jasoz) setup for same display simultaneously from rostrum to multimedia. 					
3	<p><u>Multimedia Projection Screen:</u> <u>(Qty 02)</u> Electric Multimedia Projector Screen Remote controlled Screen Size: 12' * 9' Matt White Screen aspect ratio 16:9/16:10 Accessories: Remote with batteries Warranty: One year onsite <u>Supply and Installation of Material</u> (Wall mount or Ceiling mount) Scope of Work: Supply & Installation</p> <ul style="list-style-type: none"> a) Installation of multimedia projector 	No	02			

	<p>Screen. (Complete in all respect)</p> <p>b) Installation of power cable & multi socket light plug: 40*0.0076 2 cores copper flexible. 5 In 1 multi socket light plug with PVC back box.</p> <p>c) Installation of duct or PVC pipe. Duct Size 16*38. PVC Pipe: 3/4".</p>					
4	<p><u>Network Bullet Camera: (Qty 04)</u> Network bullet camera 2MP WDR IR Mini ½.8” 2 Megapixel progressive scan STARVIS™ CMOS Resolution 1080P(1920x1080)/1.3M(1280x960)/720P(1280x720) H.265&H.264 triple-stream encoding Smart Detection supported Ethernet RJ-45(10/100Base-T) Digital Zoom 16x WDR(120dB), Day/Night(ICR),3DNR,AWB,AGC ,BLC 3.6mm fixed lens Max. IR LEDs Length 30m IP6, POE Warranty: One year onsite <u>Supply and Installation of Material</u> Scope of Work: Supply & Installation a) Installation of Network Bullet Cameras. (Complete in all respect) b) Installation of Network Cable (CAT 6 UTP 23AWG): Laying of four cables from Auditorium to IT Office. c) Installation of power cable & multi socket light plug: 40*0.0076 2 cores copper flexible. 10 In 1 multi socket light plug with PVC back box. d) Installation of duct or PVC pipe. Duct Size 40*40. PVC Pipe: 1-1/4".</p>	No	04			
5	<p><u>10 Port Unmanaged Desktop Switch with 8-Port PoE: (Qty 01)</u> Data Transmission Port: Port 1-8 8 x RJ-45 10/100 Mbps (PoE)</p>					

Signature & Stamp of Bidder

Port 9-10 2 x RJ-45 10/100/1000 Mbps (Uplink) Power Supply: 48 V- 57 V DC Capacity: 5.60 Gbps Packet Forwarding Rate:4.17 Mbps Packet Buffer Memory: 4 Mbit MAC Table Size: 8 K Communication Standard: IEE802.3/ IEE802.3u/ IEE802.3ab/ IEE802.3x PoE Standard: IEE802.3af, IEE802.3at, IEE802.3bt, Hi-PoE PoE Power: 96 W Power Consumption Management: Yes Long Distance PoE: 250 m long distance PoE transmission PoE Watchdog: Yes Warranty: One year onsite	No	01			
Grand Total (Rs.)					
Grand Total in words including all taxes, Installation and Delivery Charges					

Note:

- Duct/PVC pipe unit rate (Ten feet length) should be quoted and will be charged as per actual used.
- Network cable unit rate @ meter should be quoted and will be charged as per actual used.
- 40*0.0076 2 cores copper flexible unit rate @ meter should be quoted and will be charged as per actual used.
- Rate for HDMI cable of each size should be mentioned and will be charged as per actual no of used of each size.
- Vendor is suggested to visit the site before quoting the bid.
- The Purchase/Work order will be awarded on **Grand Total Basis.**
- Please clearly mention the quoted model/brand/technical detail otherwise your bid /items may be rejected.
- Bidders shall price the Bill of Quantities in Pakistani Rupees only.
- For all the Brands mentioned in this tender (if any), the term “or equivalent” is hereby added and shall be considered as per PPRA rules.
- Multiple prices of an item may lead to rejection of the item/bid.
- Please quote the rates on our BoQ otherwise your bid/item may be rejected.

Signature & Stamp of Bidder

Part-B-of the Tender

Bill of Quantities (BoQ) (Item Wise Basis)

Procurement of Furniture & Fixture for Auditorium of CUI, Sahiwal Campus

Sr.#	Item Name & Specification	Qty		Rates to be quoted inclusive of all taxes Installation and Delivery Charges		
				Quoted Model/Brand	Unit Price (Rs)	Total Price (Rs)
1	Floor Carpet: Provide lay and install the best quality local synthetic A class carpet of 10-12 mm thick loop pile polypropylene, approved color and shade, on floors as per drawings and as per direction of Engineer In-charge. Note: Sample required at the time of tender opening	P. Sft	3776.50			
2	Provide and Installation of Auditorium Chairs: Seat Foam Thickness: Minimum-3-Inches Back Foam Thickness: Minimum-3-Inches Seat and Back Fabric Material: Leatherette Fine Quality Please bring sample book at the time of technical bid opening) Foam Density: Minimum 50 to 60 Kg/cm ² Base Structure: M.S Plate 3"x3/8"x12", M.S Pipe 2 1/2" Dia-14-Gauge Arms to Arms Inner: 495-500mm Seat Dimension: L: 495mm W: 510mm Back Dimension: L: 510mm H: 650mm	No	252			

Signature & Stamp of Bidder

	Seat to Floor Height: from Front 520mm from Back:495mm Back to Floor Height:1040mm Arms to Floor Height:640mm Seat and Back Structure: 3/8" MDF (Back and seat cover with good quality wood and high-class finishing) appropriate gap between seat and back Arms Material: Good Quality wood 3"x3/4" (17" Length) Writing Pad: Standard High- Density wood finished Seat Mechanism: Auto Folding/Auto tip-up (when not in use) (including installation) Note: Technical committee reserves the right to check the sample in all aspects					
	Grand Total (Rs.)					
	Grand Total in words with all Taxes, Installation and Delivery Charges					

Note:

- The Purchase/Work order will be awarded on **Item Wise Basis.**
- Please clearly mention the quoted model/brand/technical detail otherwise your bid /items may be rejected.
- Bidders shall price the Bill of Quantities in Pakistani Rupees only.
- For all the Brands mentioned in this tender (if any), the term "or equivalent" is hereby added and shall be considered as per PPRA rules.
- Multiple prices of an item may lead to rejection of the item/bid.
- Please quote the rates on our BoQ otherwise your bid/item may be rejected.

Signature & Stamp of Bidder

Sheet for Evaluation of Technical Proposals of the Vendors

Sr. No	Evaluation Criteria	Provided
01	Literature of Quoted Brand	
02	Valid NTN & GST Numbers	
03	Active Taxpayer List	
04	Complete Company Profile including Year of Establishment and Client Lists	
05	Photocopies of Purchase Orders for Supply of IP Cameras/Access Points/IT Accessories/Furniture to any Federal or Provincial Government Department, Agency, Organization or autonomous body or Private Sector Organization anywhere in Pakistan	
06	Warranty Acceptance Certificate	
07	Affidavit on Judicial Stamp Paper	



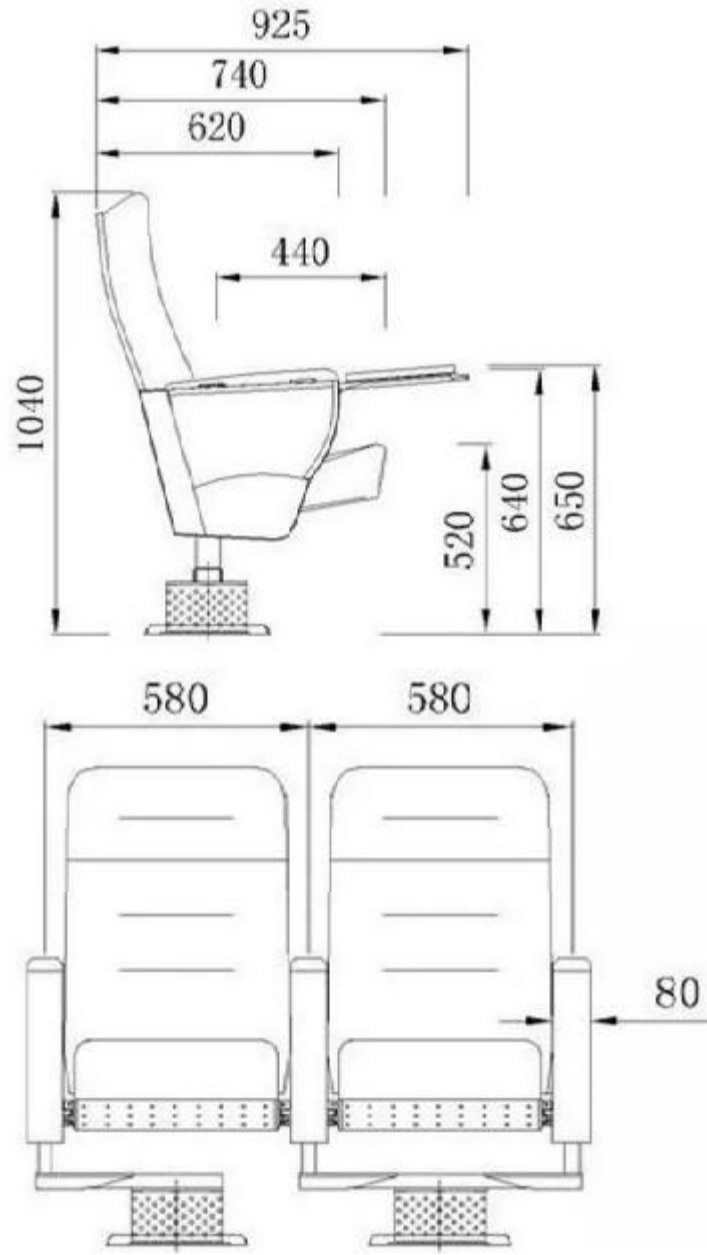

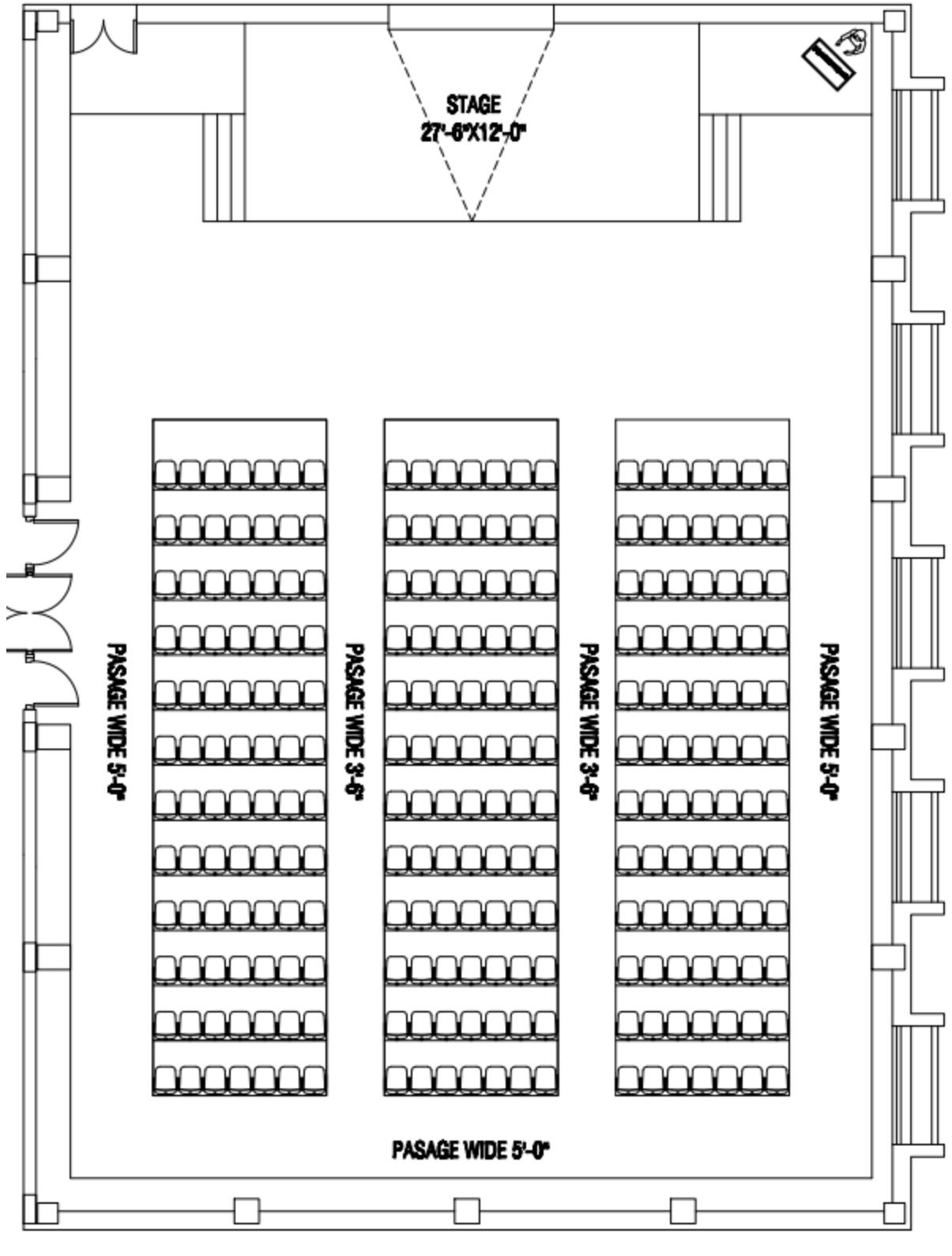

Signature & Stamp of Bidder

